

Conventional Burden for Current or Voltage Instrument Transformers

Standard current/voltage burden are developed for measuring current/voltage instrument transformers according to IEC 60044-1/2.

We offer high accurate current burden with adjustable steps up to 60 VA (IEC) or 200 VA (ANSI) or voltage burden with adjustable steps up to 318.75 VA (IEC) or 400 VA (ANSI).



Standard Current Burden



Standard Voltage Burden

For further information see next pages ⇒

Electronical Burden for Current or Voltage Instrument Transformers

The programmable electronic compensated standard current/voltage burden ESCB/ESVB can be used in transformer test laboratories for manual, semiautomatic and automatic tests of current/voltage instrument transformers.

The ESCB/ESVB is characterised particularly by the user-friendly menu guidance using function keys and 10,4" TFT- mono chrome display.



Electronical Compensated Current Burden
ESCB200



Electronical Compensated Voltage Burden
ESVB200

For further information see next pages ⇒

Standard Current Burden

Features:

- LED indication for the selected burden steps ¹
- Internal or external control selectable by rotary switch ¹
- Selecting the previous or next burden step by buttons ¹ or rotary switches ²
- Manual ² or computer-controlled ¹ selection of the burden step
- Switching under load ^{1 2}



SCB30-2R-I

Technical Data

Example: SCB60-2M-I	
Nominal current I_N	1 A and 5 A
Frequency	50 Hz (optional: 16 2/3 Hz or 60 Hz)
Test voltage	2 kV, 1 min
Burden range	1 ... 120 % I_N or 1 ... 200 % I_N
Error	$\leq \pm 3 \%$
Burden steps	$\cos\beta = 1 : 1 - 1.25 - 1.5 - 2 - 2.5 - 3.75 \text{ VA}$ $\cos\beta = 0.8 : 5 - 6.25 - 7.5 - 10 - 11.25 - 15 - 20 - 25 - 30 - 45 - 60 \text{ VA}$

Standard Voltage Burden

Features:

- Each burden step can be selected over the range 0 ... 318.75 VA in steps of 1.25 VA ^{1 2}
- Load range 80 ... 120 % U_N ^{1 2}
- Accuracy in the load range $\leq \pm 3 \%$ ^{1 2}
- Manual ² or computer-controlled ¹ selection of the burden step



SVB318-6M-I

Technical Data

Example: SVB318-6M-I								
Nominal voltage U_N	100 V, 100/3 V, 100/√3, 110 V, 110/3 V, 110/√3							
Frequency	50 Hz (optional: 60 Hz)							
Test voltage	2 kV, 1 min							
Burden range	80 ... 120 % U_N							
Error	$\leq \pm 3 \%$							
Burden step ranges	0 ... 318.75 VA in steps of 1.25 VA							
Burden steps can be selected in any required combination by switches A, B, C and D (max. burden 318.75 VA) in steps of 1.25 VA.								
Burden steps	Switch	Steps						
	A	0	1.25	2.5	3.75	VA	$\cos\phi = 0.8$	
	B	0	5	10	15	VA	$\cos\phi = 0.8$	
	C	0	20	40	60	VA	$\cos\phi = 0.8$	
	D	0	80	160	240	VA	$\cos\phi = 0.8$	
max. burden 318.75						VA		

¹ This applies for the remote controlled burden (R)

² This applies for the manually burden (M)

Syntax for Conventional Burden

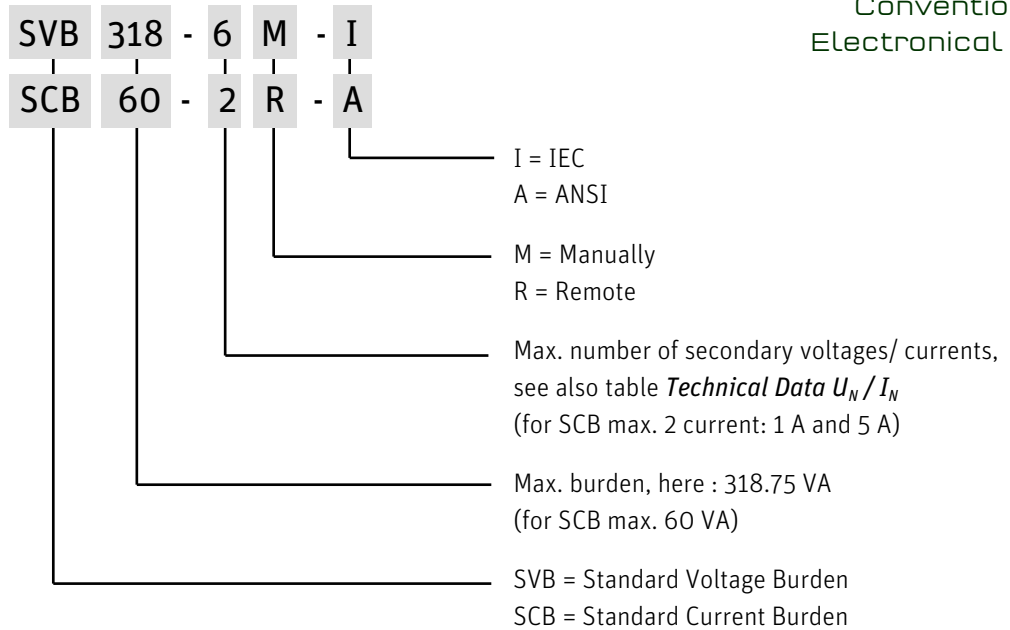

Electronic Compensated Current Burden

ESCB200

Features:

- No external burden adjustment required
- The menu-guided control of the ESCB can be accomplished either by using an external PC or the built-in soft-key terminal.
- Calibration in the range of its specifications (e.g. IEC or ANSI) for every transformer.
- Definitions of any new standards are possible.



Technical Data

ESCB200				
General				
Power supply	230 VAC $\pm 10\%$, 47 Hz ... 63 Hz			
Power consumption	approx. 425 VA			
Dimensions (HxWxD)	350 x 483 x 580 mm			
Weight	approx. 68 kg			
Technical Specifications				
Test current I_N	1 - 2 - 5 A			
Burden steps	0,01 VA and $\cos \beta 0,01$ The burden steps can be selected in the range of 1 ... 200 VA in steps of 0.01 VA:			
	IEC50 und 50Hz User	50Hz 1 A, 2 A, 5 A	$\cos \beta 0,5 - 1$ $\cos \beta 1$	= 5 ... 90 VA = 1 ... 5 VA
	IEC60 und 60Hz User	60 Hz 1 A, 2 A, 5 A		
	ANSI	60Hz, 5 A	$\cos \beta 0,5 - 1$	= 1 ... 200 VA
max. load range	200 % I_N			
Accuracy within the load range ¹	$(\Delta R / Z)$ or $(\Delta X / Z) \leq \pm 3\%$			
Test frequency	50 Hz / 60 Hz			
Interface	1 RS232			

¹ related to Z



Electronic Compensated Voltage Burden

ESVB200

Features:

- No external burden adjustment required
- The menu-guided control of the ESVB can be accomplished either by using an external PC or the built-in soft-key terminal.
- Calibration in the range of its specifications (e.g. IEC or ANSI) for every transformer.
- Definitions of any new standards are possible.

Software

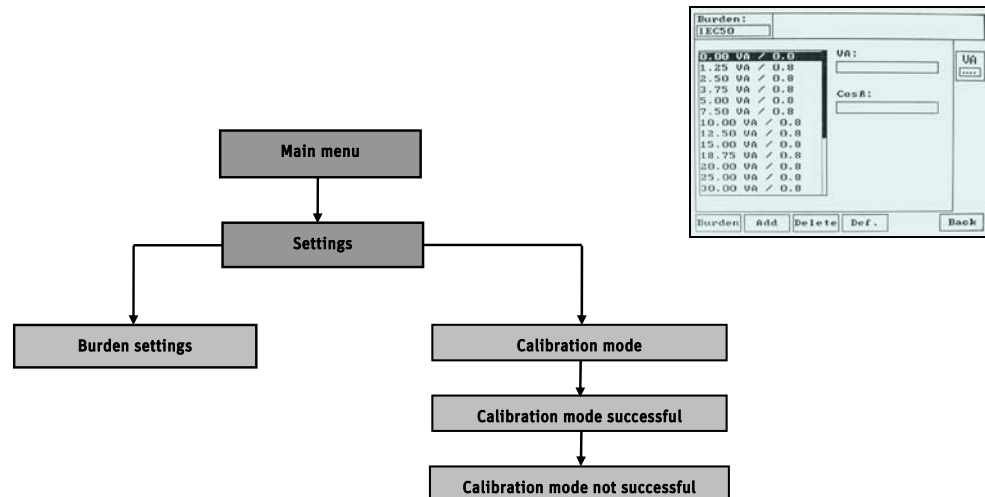

Technical Data

ESVB200	
General	
Power supply	230 VAC -15 % ... +10 %, 47 Hz ... 63 Hz
Power consumption	approx. 110 VA
Dimensions (HxWxD)	310 x 483 x 580 mm
Weight	approx. 53 kg
Technical Specifications	
Test voltage U_N	100 V, 110 V, 115 V, 120 V, 190 V, 200 V 100/3 V, 110/3 V, 115/3 V, 120/3 V, 190/3 V, 200/3 V 100/ $\sqrt{3}$ V, 110/ $\sqrt{3}$ V, 115/ $\sqrt{3}$ V, 120/ $\sqrt{3}$ V, 190/ $\sqrt{3}$ V, 200/ $\sqrt{3}$ V
Burden steps	The burden steps can be selected in the range of 0 ... 200 VA in steps of 0.01 VA and $\cos \beta$ 0.01 $\cos \beta$ 0.7 - 1 : 1 ... 200 VA $\cos \beta$ 0.5 - 1 : 2.5 ... 200 VA $\cos \beta$ 0.3 - 1 : 5 ... 120 VA $\cos \beta$ 0.2 - <0,3 : 7.5 ... 120 VA $\cos \beta$ 0.1 - <0,2 : 10 ... 25 VA
Accuracy within the load range ¹	$(\Delta R / Z)$ or $(\Delta X / Z) \leq \pm 3 \%$
Test frequency	50 Hz / 60 Hz
Interface	1 RS232

¹ related to Z