

ZERA



ITTS – Transformer Test Systems

Stationary and Mobile Transformer
Test Systems

Electronic Voltage Regulating Units
Measuring Bridges for Current and
Voltage Transformers

Conventional and Electronic Burden
Software for Mobile and Stationary
Transformer Testing



Further information to the products and product-lines presented in this catalogue can be found in the following leaflets or on our website:

- Conventional and electronic burden
- Measuring bridges for current and voltage transformers WM3000U/I
- Mobile transformer testing systems
- „Methods of Instrument Transformer Testing are Changing“ (article)

Visit our website: www.zera.de

ITTS_Proc_EXT_GB_V103

Status: 24th August 2010

Subject to alteration.

© Copyright 2010 ZERA GmbH

ZERA GmbH

Hauptstraße 392

53639 Königswinter

Germany

Phone.: +49 (0) 2223 704-0

Fax: +49 (0) 2223 704-70

E-mail: info@zera.de

www.zera.de

Table of Contents	Page
ITTS – Instrument Transformer Test Systems	5
Introduction	5
Principle of Accuracy Testing of CT and VT	6
Possible Tests for CT/VT	7
Interturn Insulation Test (CT)	7
Demagnisation (CT)	7
Polarity Check (CT/VT)	7
Accuracy Test (CT/VT)	7
Mode of Operation	8
ITTS – Stationary and Mobile Instrument Transformer Test Systems	9
CT/VT testing components	9
Stationary ITTS	9
Mobile ITTS	9
Conventional Burden SCB/SVB	10
Electronical Burden ESCB/ESVB	10
Standard Current Module SCM	10
Generating Current Transformer GCT	11
Standard Current Transformer SCT	11
High Voltage Transformer HVT	11
Standard Voltage Transformer SVT	11
Measuring Bridge WM	11
Source and Measuring Cabinets for ITTS	15
Voltage Regulating Transformer VRT	16
Electronic Voltage Regulating (and Measuring) Unit EVR(M)U	17
Software CheckCon	19

ITTS – Instrument Transformer Test Systems

Introduction

ZERA manufactures components and complete testing system for testing laboratories, to test instrument transformers, with an experience of more than 25 years. We are supplier of world-wide customers, manufactures of instrument transformers as well as electricity boards.

The system details are described in the following clauses to provide basic information. But nevertheless it is possible to develop or adapt our system for customer's requirements.



In addition to the facility for the generation of the desired current and/or voltage, a measuring set-up for the verification of instrument transformers for invoicing comprises a standard instrument transformer testing set and a standard burden. The standard instrument transformer serves as a reference, i.e. the difference between standard instrument transformer and instrument transformer is the measure for assessing the accuracy. The difference is determined with an instrument transformer testing set, kind of balance for AC currents and voltages and the standard burden is used to simulate the loading of the instrument transformer by the electricity meters connected in series and the supply leads. These devices are checked at regular intervals at the PTB for compliance with requirements.¹

ZERA configures instrument transformer testing systems for Current Transformers (CT) or Voltage Transformers (VT) testing as well as combined testing systems for CT and VT testing. ZERA's testing systems can be designed for testing instrument transformer manuell or automatic.



Individual testing (one by one)



Successive testing (charge)



Successive testing (charge)



Successive testing (charge) – details

¹ Literature: PTB Testing Instructions, volume 12, Instrument Transformers, 1977, with amendments 5/79

Principle of Accuracy Testing of CT and VT

Basic principle of accuracy testing is a comparison of unknown CT/VT with a high precision standard CT/VT. This comparison is performed with most precision microprocessor based comparator which 20 bit dual ADCs allows the precise detection of signal of standard CT/VT and CT/VT under test.

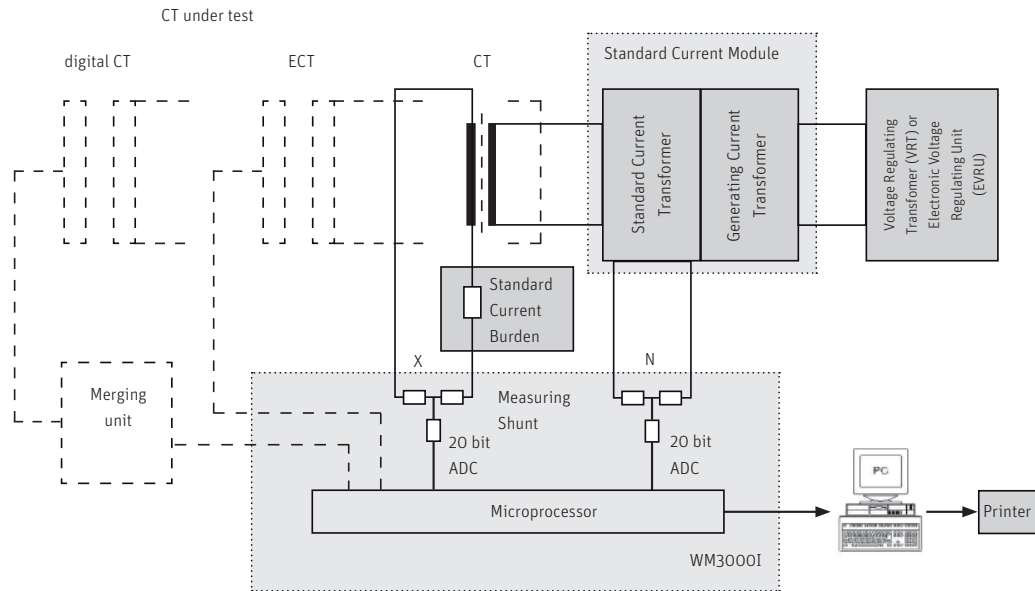

Accuracy Testing of CT/ECT, Rogowski coils and digital CT

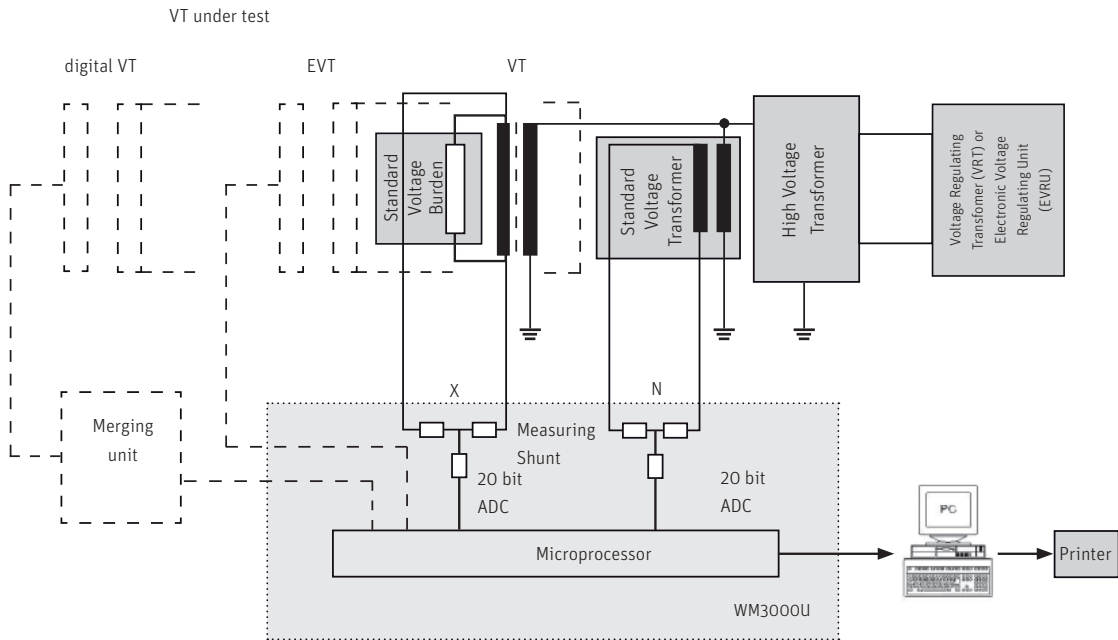

Accuracy Testing of VT/EVT and digital VT

Possible Tests for CT/VT

Interturn Insulation Test (CT)

Only one CT will be tested with an open secondary winding and a primary current up to $1 \times I_N$ or $1.2 \times I_N$ RMS (1 minute). The peak voltage on the secondary winding of the CT will be measured by a high-impedance peak-voltage meter. The primary current increases until $1 \times I_N$ or $1.2 \times I_N$ continuously or stops, if the peak voltage of the CT reaches 4.5 kV on the open secondary winding. This high voltage of 4.5 kV usually appears only during a test with CTs, which have an extreme ratio, e. g. 1000 A : 1 A. Continuous decrease of the current to zero after the test.

Demagnetisation (CT)

The demagnetisation will be performed generally for preparation of CTs for accuracy test. The current should be increased carefully e.g. up to 5 % while the CTs are secondary open.

Polarity Check (CT/VT)

This procedure checks the polarity between primary and secondary winding and guarantees the correct direction of energy flow. The polarity check takes place before the accuracy test.

Accuracy Test (CT/VT)

Carry out the accuracy test with free selectable test points e. g. 120 – 100 – 20 – 5 – 1 % I_N (CT) or 80 – 100 – 120 % U_N (VT) with the corresponding burden steps. A load point table can be prepared and entered according to own standards.

Process of CT/VT Testing

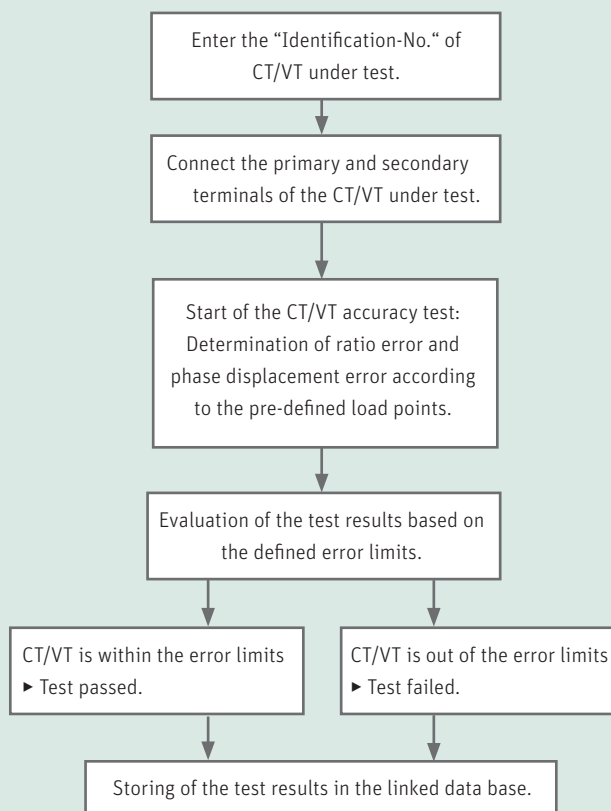

Process of CT/VT Testing

The test compares the ratio error of the CT or PT under test with the standard transformer of the test equipment. The result of ratio error and phase displacement will be indicated.

The comparison takes place in a self-calibrating comparator (measuring bridge).

The PC shows the following measurement results:

- Rated current (% I_N) / rated voltage (% U_N)
- Ratio error (%)
- Phase displace error (min)
- Frequency (Hz)

The PC stores the measurement results. The results are compared with the error values corresponding to the accuracy class. Finally a test protocol represents the results.

CTs or PTs, which errors are outside the allowable limits are marked as FAIL.

Mode of Operation

- The operator has to insert the identification-numbers of the VT or CT under test and to connect the primary and secondary terminals of the VT or CT.
- Then the operator can start the test, which will be done automatically the accuracy-test normally begins with the lowest (VT) or highest (CT) test point.
- To the next test point the voltage/current will be regulated up subsequently after the last test point the test voltage is regulated down to zero.
- To the next test point the voltage/current will be regulated up subsequently after the last test point the test voltage is regulated down to zero.
- If the VT or CT is completely tested the operator has to disconnect the tested VT or CT.
- After all tests the software application presents the test-results and all results will be stored in the data base.

All operations of the source, switches of burden and mode selections must be done in case of a manual test equipment manually. In case of an automatic test equipment, this will be done automatically, controlled by PC and PLC.



ITTS Singapore

ITTS – Stationary and Mobile Instrument Transformer Test Systems

Stationary and mobile instrument transformer test systems from ZERA are developed for testing current instrument transformers (CT) and voltage instrument transformers (VT). Stationary test systems are available for manual or automatic operation.

Transformer testing serves for the accuracy test including polarity check and demagnetisation for current and voltage transformers in low-voltage, middle-voltage and high-voltage grids according to IEC standard 60044-1, 60044-2, 60044-7, 60044-8 and 61850-9-2 or ANSI IEEE C57.13.

CT/VT testing components

Measuring bridge for current / voltage transformers – WM3000U/I

Electronic compensated current / voltage burden – ESCB/ESVB200



Stationary ITTS

Stationary CT/VT test system

Stationary, automatic CT/VT test system



Customized connection table



Mobile ITTS

Mobile CT test system

Standard/High voltage transformer SVT/HVT

VRT for generating the required voltage





CT/VT Testing Components

Conventional Burden | SCB/SVB

- Standard current/voltage burden for measuring current/voltage instrument transformers according to IEC 60044-1/2
- Standard Current Burden SCB with adjustable steps up to 60 VA (IEC) or 200 VA (ANSI)
- Standard Voltage Burden SVB with adjustable steps up to 318,75 VA (IEC) or 400 VA (ANSI)

▶▶▶ For further information to this products please see external leaflet. ▶▶▶

Electronical Burden | ESCB/ESVB

- Electronical compensated current or voltage burden ESCB/ESVB for manual and automatic test of current/voltage instrument transformers.
- User-friendly menu guidance
- 10,4" TFT-mono chrome display
- ESVB/ESCB with adjustable steps up to 200 VA (IEC and ANSI)

Standard Current Module | SCM

- Standard current module SCM consisting of generating current transformer GCT and standard current transformer SCT
- Cost-effective and space-saving combination of GCT and SCT
- Less wiring due to fixed wiring inside
- Time-saving due to one-off connection of GCT and SCT
- Example SCM3000-120*:
 - Max. current 3840 A
 - Max. output power 16 kVA

* other customer requirements on request

Generating Current Transformer | GCT

- The GCT for generating the test current for accuracy testing of current transformers
- Example GCT6000*:
 - Max. output power 36 kVA
 - Max. test current 6000 A

Standard Current Transformer | SCT

- The values of the CT under test will be compared with the values of the standard current transformer SCT.
- Example SCT6000*:
 - I_{Nsec} 5 A
 - Load range 1 ... 120 %
 - Max. current 7200 A

High Voltage Transformer | HVT

- High voltage transformer HVT for generating the test voltage for accuracy testing of voltage transformers.

Standard Voltage Transformer | SVT

- Standard voltage transformer SVT for testing voltage transformer with single and double-pole connections.

Measuring Bridge | WM

- The current/voltage measuring bridges WM3000I/U are high-precision comparator units for comparing secondary signal from transformer under test (or digital information of non-conventional transformers) with a reference signal supplied by a standard device.
- Display of measuring values and control of the test procedure via touch screen.

* other customer requirements on request



▶▶▶ For further information to this products please see external leaflet. ▶▶▶



Example of current transformer testing from 4000 A up to 6000 A.

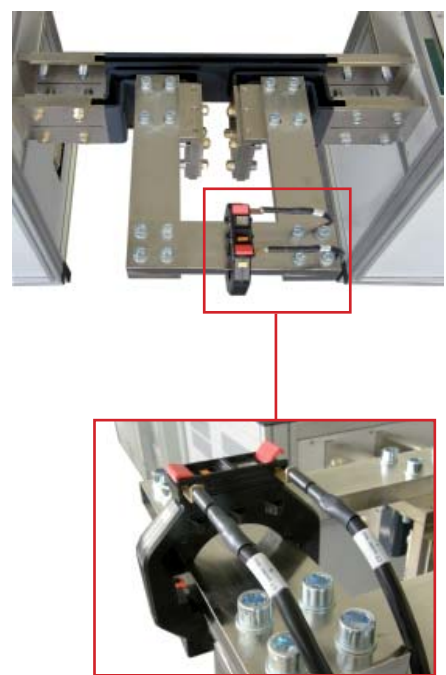

Detail of the CT under test connected at the secondary side.

Stationary ITTS

- Measuring of voltage/current transformers (low-, middle- and high-voltage)
- Accuracy test, polarity check, interturn insulation test and demagnetisation.
- CT one-by-one testing

Example for low and middle voltage instrument transformer CT/VT testing*:

- Mains voltage: 3 x 230 V/400 V, (50) 60 Hz
- Output voltage: 0 ... 400 V
- Output power: max. 30 kVA
- Suitable for the following CTs:
 - $I_N = 5 \dots 6000 \text{ A}$
 - Max. $I_{Prim} = 120 \% \text{ of } I_N$
 - Secondary current: 5 A
 - Max. burden of CT under test: 200 VA
- Suitable for the following VTs:
 - $U_N = 120 \text{ V} \dots 100 \text{ kV}$
 - Max. $U_{Prim} = 120 \% \text{ of } U_N$
 - Secondary voltages: 120 V, 115 V, 69 V
 - Max. burden of VT under test: 200 VA
- Used components amongst others:
 - Regulating transformer (variac)
 - ESVB200/WM3000U
 - ESCB200/WM3000I
 - Generating current transformer GCT6000
 - Standard current transformer SCT6000
 - High voltage generating transformer HVT130
 - Standard voltage transformer e. g. SVT100

* other customer requirements on request

Mobile ITTS for CTs and VTs

- Testing of current /voltage transformers in low-, middle- and high-voltage grids
- Accuracy test, polarity check and de-magnetisation
- Example voltage transformer*:
 - $U_N = 110/\sqrt{3}$ kV
 - Max. $U_{Prim} = 120\%$ of U_N
 - Secondary voltages
100/ $\sqrt{3}$ V, 110/ $\sqrt{3}$ V, 100 V, 110 V
 - Max. burden of the voltage transformer under test 158,75 VA
- Example current transformer*:
 - $I_N = 4000$ A
 - Max. $I_{Prim} = 120\%$ of I_N
 - Secondary currents: 5 A and 1 A
 - Max. burden of the current transformer under test 60 VA
- Used components amongst others:
 - Voltage Regulating Transformer VRT
 - Standard Current Module SCM4000-120
 - Measuring Bridge WM303-I
 - Electronic compensated Current Burden ESCB200

▶▶▶ For further information to this products please see external leaflet. ▶▶▶

Voltage Regulating Transformer VRT

- Voltage Regulating Transformer VRT for supply of the high voltage or high current transformer testing with variable voltage for testing of CTs/VTs

* other customer requirements on request



Assembly for high voltage measurement



Remote control for safe operation





Detail current transformer testing

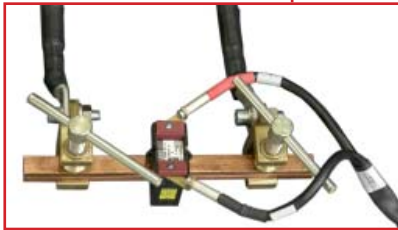

Voltage regulating transformer VRTm2-40-40



Mobile ITTS for CTs

- Testing of current transformers in low-, middle- and high-voltage grids
- Accuracy test, polarity check and de-magnetisation
- Example current transformer*:
 - $I_N = 5 \text{ A}$ up to 300 A
 - Max. $I_{\text{Prim}} = 120 \% \text{ of } I_N$
 - Secondary currents: 5 A and 1 A
 - Max. burden of the current transformer under test 30 VA
- Used components amongst others:
 - Voltage regulating transformer VRT
 - Standard current transformer SCT
 - Generating current transformer GCT
 - Measuring equipment ME

VRTm2-40-40

- Voltage regulating transformer VRT to transform a fixed input voltage (400 V) to a variable output voltage (0 ... 400 V)
- The VRT feeds the generating current transformer GCT with a variable input voltage
- A control panel with all operating elements for the manual operation is placed on top of the VRT

▶▶▶ For further information to this products please see external leaflet. ▶▶▶

MEM30

- The mobile measuring equipment MEM30 is equipped with
 - Standard current burden SCB30
 - Measuring bridge WM303-I
 - Mobile PC

* other customer requirements on request

Source and Measuring Cabinets for ITTS

The electronic voltage regulating unit EVRU or the voltage regulating transformer VRT feeds variable voltage to the voltage or current generating transformers to generate the test current/voltage for automatic or manual testing of CT/VT.





Detailed view

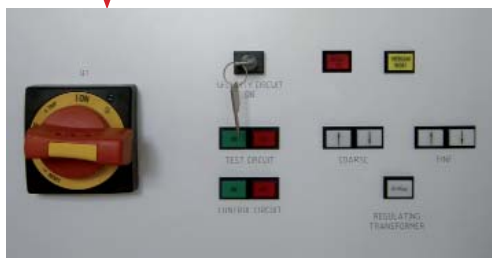

Operation panel at the front side of the VRT



Standard current transformer SCT6000

Voltage Regulating Transformer VRT

The VRT feeds a variable voltage to the high voltage or high current generating transformer for manual testing of CT/VT.

The output voltage is adjusted manually or by push-buttons at control desk.

- Mains voltage: 3 x 230 V / 400 V
- Frequency: 50 Hz or 60 Hz
- Output voltage: 0 ... 400 V
- Output power: 10 up to 100 kVA*
* based on the power requirement for high voltage and current generating unit

The measuring cabinet consists of e. g.:

- Measuring unit WM303U/I or WM3000U/I
- SCB or ESCB200
- SVB or ESVB200
- Peak voltmeter
- PC

The instrument housing of the cabinet is equipped with e. g.:

- 1 analogue voltmeter Cl. 1, connected to the secondary side of the SVT
- 1 analogue ammeter Cl. 1, connected to the secondary side of the SCT

All operating elements for the manual operation are mounted on the cabinet-front (or at the external cable-connected remote control):

- Main switch
- Emergency stop switch
- push buttons for
 - Control circuit ON/OFF
 - Test circuit ON/OFF
 - Control switch for the generating transformer unit
- Safety circuit
- Selector for I_N and U_N
- Balance burden for U_{sec} and I_{sec} circuits

Electronic Voltage Regulating (and Measuring) Unit EVR(M)U

The EVR(M)U feeds variable voltage to high voltage and/or current generating transformers.

The source is equipped with cable-connected remote control or with push buttons.

Design of the source cabinet as 19" cabinets (depending on the output power).

- Mains voltage: 3 x 230 V / 400 V
- Frequency: 50 Hz or 60 Hz
- Output voltage: 0 ... 400 V
- Output power: 8 kVA 80 kVA

The source cabinet is equipped with the following additional units:

- Amplifiers of series V140
- Control unit SES250

The configuration of the measuring cabinet is similar to the measuring cabinet of the VRT (see previous page).

All operating elements for the manual operation are mounted on the cabinet-front (or at the external cable-connected remote control).

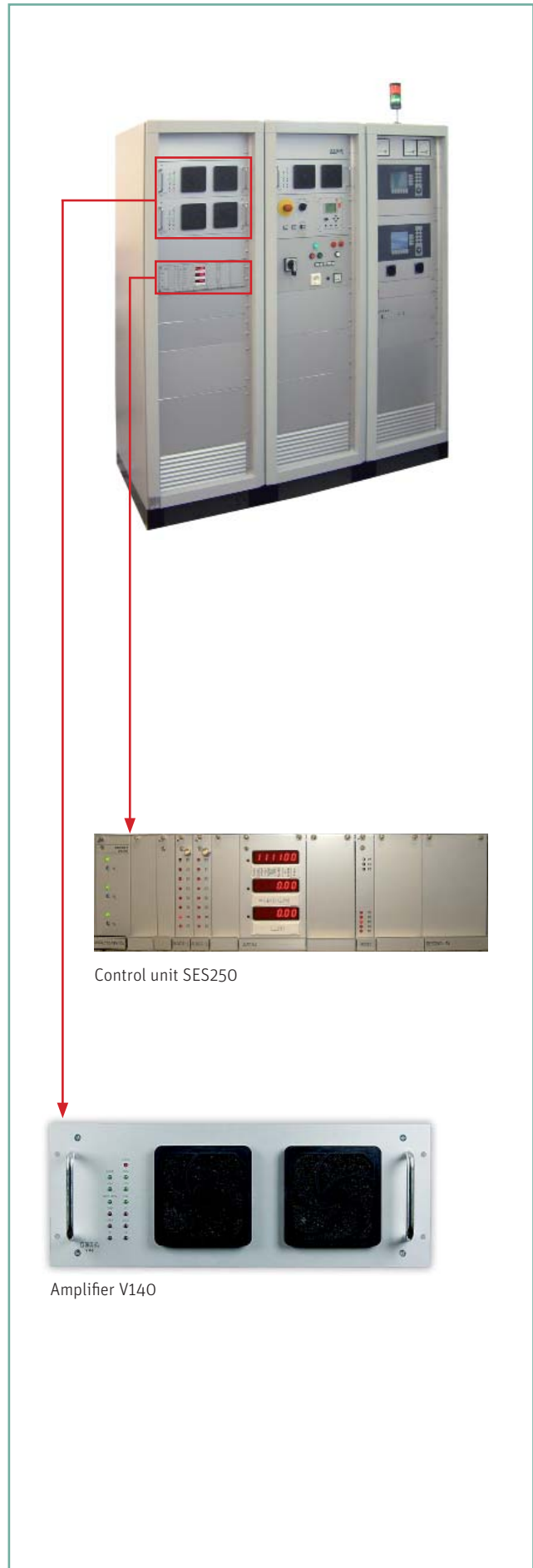

Software CheckCon

Optionally the advanced software package CheckCon is available. This software offers manual or automatic control of a test procedure depending on the hardware. Minimum requirement: external PC (e. g. notebook), Windows system (XP or higher) software and RS232 interfaces.

Data management of CTs/VTs under test, test tables and test results will be done by integrated MS Access runtime module.

The following functions are available for the user:

- Enter the details of CT/VT under test (type table)
- Enter the error class table
- Prepare the test sequence table including load points, burden acceptance criteria etc.
- Conduct the testing in automatic or manual way
- Evaluate the results of CT/VT under test
- Compensation of error of standard CT/VT
- Printout of the test reports
- Possibility to connect a labelprinter
- Possibility to connect a barcode scanner to read the serial number and property number
- Possibility to transfer the test results to a host computer

In manual mode the operator sets the load point and performs the measurement. The results are not stored or printed out.

In automatic mode the PC guides the operator to make manual regulations and operations during all tests and stores the results.

The software language is in English or German.



Automatic test procedure

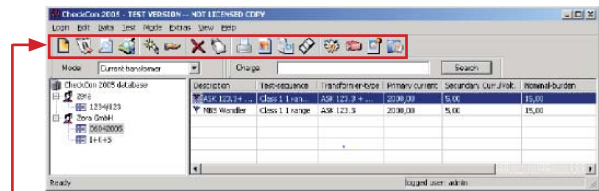

Important functions are adjustable via speed buttons

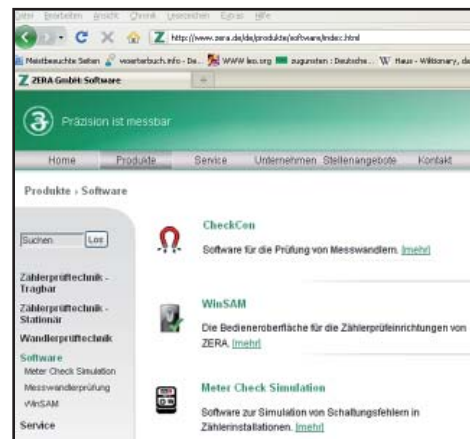

Visit us on our website.

